

"EVOLUTION LINE"

NEW!



TCH-R800

TRACKED MINIDUMPER

 **MESSERSSI** S.p.A.

GENERAL FEATURES

- Tracked undercarriage with hydrostatic transmission and oscillating rollers in the center of the track for overcoming obstacles.
- The layout of the rubber track provides a wide area and a low ground pressure, high stability and an excellent driving comfort in all conditions of use.
- 13 hp water-cooled Kubota Diesel engine or 16 hp Briggs&Stratton petrol engine and electric start.
- Hydrostatic transmission with two piston pumps with variable displacement and two orbital motors. Steering by the rotation of the tracks.
- The selfloading shovel of 65 lit. of capacity (option) allows an optimal loading of the body.
- Available with dumping skip with 180° swiveling discharge.
- Hydraulic power take off (P.T.O.) double-effect with max delivery 28 l/min and pressure at 155 bar (optional).
- Standard bonnet and operator platform.

TECHNICAL DATA

	MTP	CA	BT	AVP
- Operational weight (without operator) kg	630	540	670	770
- Load capacity: - heaped (SAE Standard) m ³	0,41	0,30	0,45	0,28
- flat: sand m ³	0,36	0,21	0,36	0,24
- liquid m ³	0,10	0,21	0,25	0,20
- Max payload kg	800			

TECHNICAL DATA

- Diesel Engine		Kubota Z482
- Displacement	cm ²	479
- Cylindres	n°	2
- Max. power at maximum speed	kW/Hp	9.6 / 13
- Maximum engine rotation	rpm	3600
- Max. torque at 2600 rpm	daNm	3.0
- Petrol Engine		Briggs&Stratton Vanguard 16HP V-Twin
- Displacement	cm ²	450
- Cylindres	n°	2
- Max. power at maximum speed	kW/Hp	12 / 16
- Maximum engine rotation	rpm	3600
- Max. torque at 3200 rpm	daNm	3.3
- Cooling	type	water
- Battery		12V - 55 Ah
- Piston pumps with variable displacement for the transmission		2 x 29 lt / min at 250 bar
- Gear pump for the services		1 x 21 lt / min at 160 bar
- Track width	mm	180
- Separate tracks steering system		
- Track tensioning	type	spring + screw
- Specific ground pressure: empty / loaded	kg/cm ²	0.18 / 0.48
- Max speed	km/h	4.0
- Max gradient capacity fully load	%	62
- Fuel tank capacity	lt	9.7
- Hydraulic oil tank capacity	lt	22.1

OVERALL DIMENSIONS

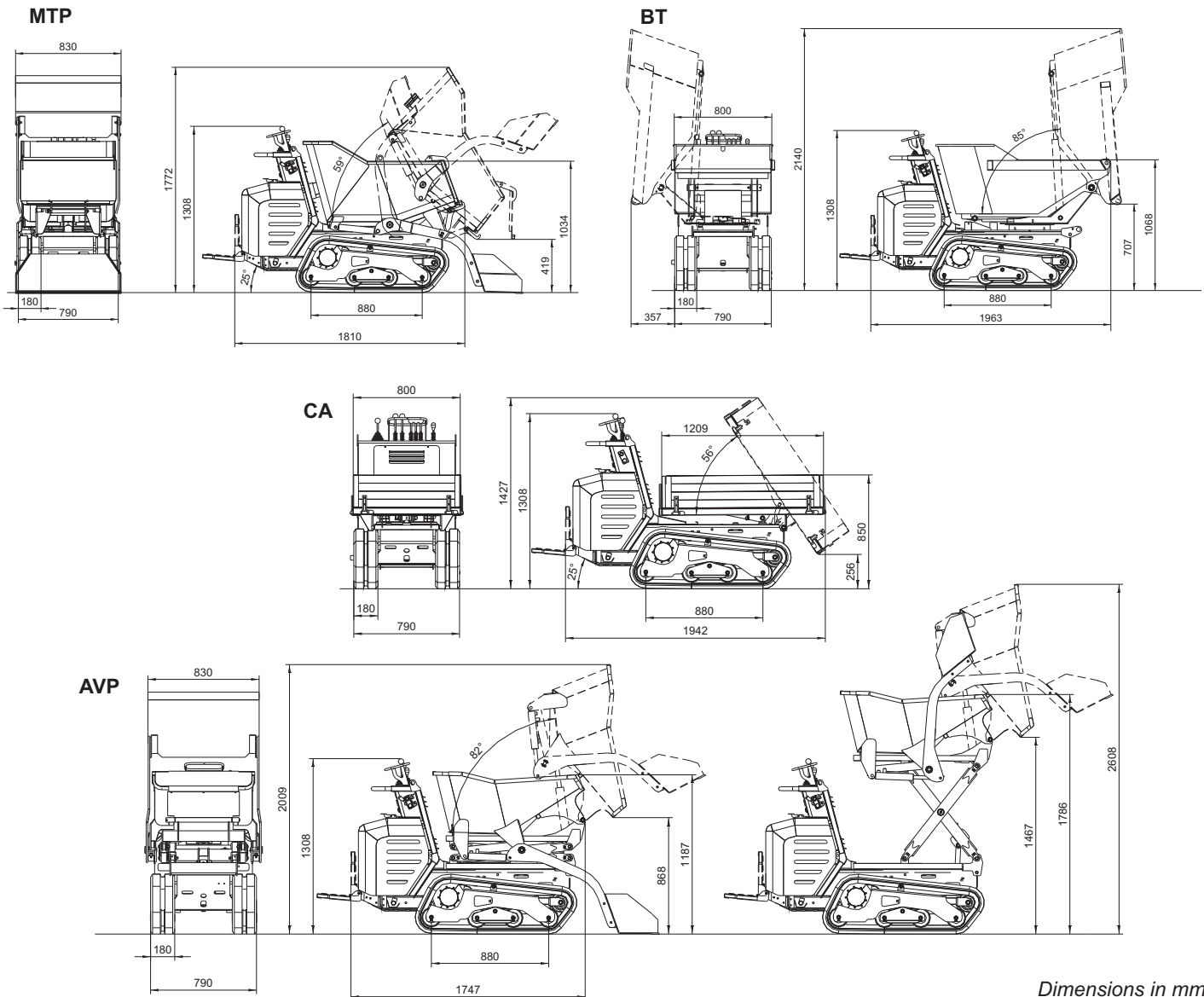

Data, features and pictures are not binding and may be altered without any prior notice.



MESSERSI S.p.A.

Via Arcevese, 44 - 60010 CASINE di OSTRÀ (AN) Italy
Web: www.messersi.it E-mail: export@messersi.it

Tel. +39.071.688771 r.a. - Fax +39.071.688586

